

Series 31 Lug

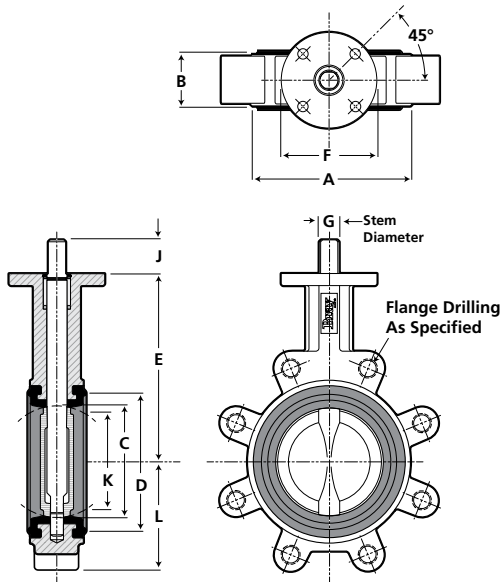

Series 30 Wafer

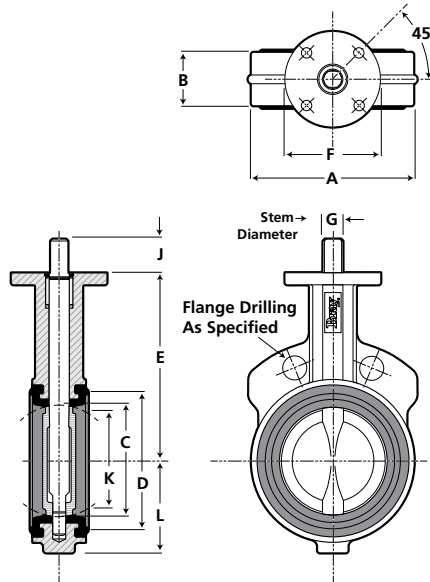

IMPERIAL DIMENSIONS: Inches																	Lug Bolting Data				
Valve Size	A	B	C	D	E	F	Top Plate Drilling			G	H	J	K	L		Adapter Code	Weight (lbs.)		Bolt Circle	No of Holes	Threads ISO Coarse
							BC	No of Holes	Hole Diameter					Wafer	Lug		Wafer	Lug			
2	3.69	1.62	2.00	2.85	5.50	3.54	2.76	4	.39	.55	.39	1.25	1.32	2.22	2.30	A	5.5	7.0	4.75	4	.62-11
2½	4.19	1.75	2.50	3.36	6.00	3.54	2.76	4	.39	.55	.39	1.25	1.91	2.47	2.57	A	7.0	8.0	5.50	4	.62-11
3	4.88	1.75	3.00	4.15	6.25	3.54	2.76	4	.39	.55	.39	1.25	2.55	2.81	2.81	A	7.5	9.0	6.00	4	.62-11
4	6.06	2.00	4.00	5.16	7.00	3.54	2.76	4	.39	.63	.43	1.25	3.57	3.41	4.09	B	11.5	15.0	7.50	8	.62-11
5	7.06	2.12	5.00	6.16	7.50	3.54	2.76	4	.39	.75	.51	1.25	4.63	4.03	4.61	C	14.0	20.0	8.50	8	.75-10
6	8.12	2.12	5.75	7.02	8.00	3.54	2.76	4	.39	.75	.51	1.25	5.45	4.53	5.06	C	17.0	23.0	9.50	8	.75-10
8	10.50	2.50	7.75	9.47	9.50	5.91	4.92	4	.57	.87	.63	1.25	7.45	5.75	6.05	D	34.0	42.0	11.75	8	.75-10
10	12.75	2.50	9.75	11.47	10.72	5.91	4.92	4	.57	1.18	.87	2.00	9.53	7.12	7.69	E	49.0	66.0	14.25	12	.88-9
12	14.88	3.00	11.75	13.47	12.25	5.91	4.92	4	.57	1.18	.87	2.00	11.47	8.12	9.02	E	67.0	88.0	17.00	12	.88-9

Note: K dimension is disc chordal dimension at valve face.

METRIC DIMENSIONS: Millimeters																	Lug Bolting Data				
Valve Size	A	B	C	D	E	F	Top Plate Drilling			G	H	J	K	L		Adapter Code	Weight (Kg)		Bolt Circle	No of Holes	Threads ISO Coarse
							BC	No of Holes	Hole Diameter					Wafer	Lug		Wafer	Lug			
50	94	41.2	51	72	140	90	70	4	10	14	10	32	34	56	58	A	2.5	3	121	4	.62-11
65	106	44.5	64	85	152	90	70	4	10	14	10	32	49	63	65	A	3	3.5	140	4	.62-11
80	124	44.5	76	102	159	90	70	4	10	14	10	32	65	71	71	A	3.5	4	152	4	.62-11
100	154	50.8	102	131	178	90	70	4	10	16	11	32	91	87	104	B	5	7	191	8	.62-11
125	181	54.0	127	156	190	90	70	4	10	19	13	32	118	102	117	C	6	9	216	8	.75-10
150	206	54.0	146	178	203	90	70	4	10	19	13	32	138	115	129	C	8	10	241	8	.75-10
200	267	63.5	197	240	241	150	125	4	14	22	16	32	189	146	154	D	15	19	298	8	.75-10
250	324	63.5	248	291	273	150	125	4	14	30	22	51	242	181	195	E	22	30	362	12	.88-9
300	378	76.2	298	342	311	150	125	4	14	30	22	51	291	206	229	E	30	40	432	12	.88-9

Note: K dimension is disc chordal dimension at valve face.

Drawings are for reference only. Bray reserves the right to change product dimensions without notice.

Series 30 Wafer

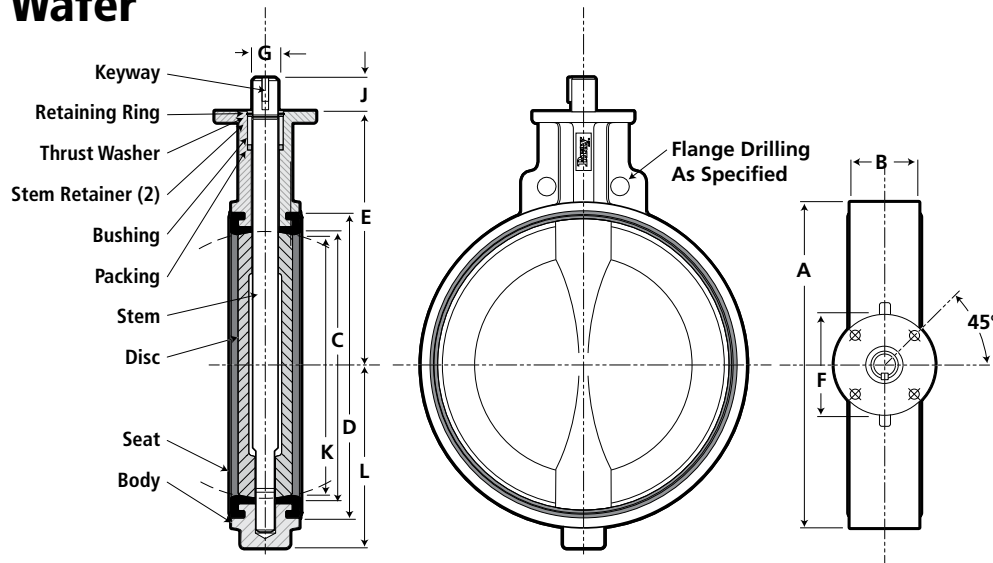

Series 31 Lug

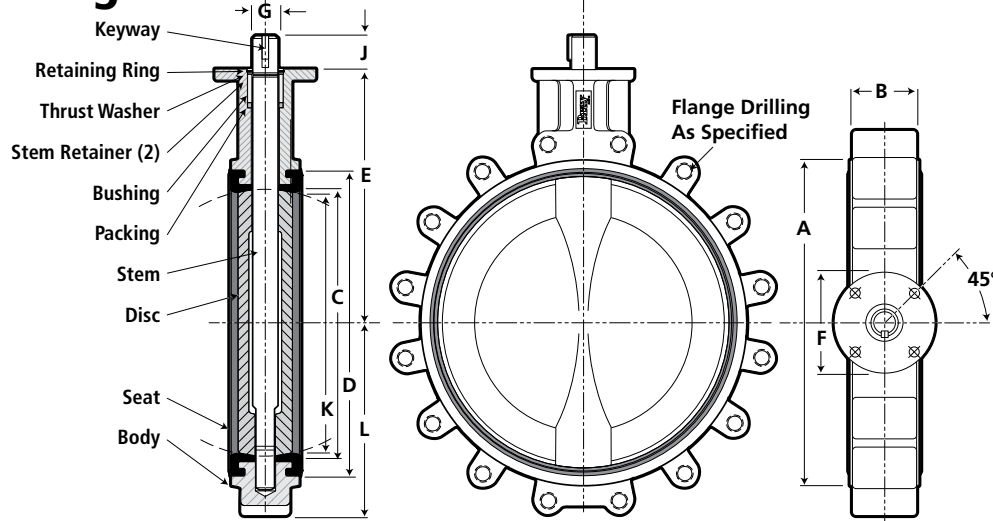

IMPERIAL DIMENSIONS: Inches																	Lug Bolting Data				
Valve Size	A	B	C	D	E	F	Top Plate Drilling			G	J	Key Size	K	L		Adapter Code	Weight (lbs.)		Bolt Circle	No of Holes	Threads ISO Coarse
							BC	No of Holes	Hole Diameter					Wafer	Lug		Wafer	Lug			
14	17.05	3.00	13.25	15.28	13.62	5.91	4.92	4	.57	1.38	2.00	.39x.39	13.04	9.38	9.93	F	95	114	18.75	12	1.00-8
16	19.21	4.00	15.25	17.14	14.75	5.91	4.92	4	.57	1.38	2.00	.39x.39	14.85	10.75	11.30	F	135	166	21.25	16	1.00-8
18	21.12	4.25	17.25	19.47	16.00	8.27	6.50	4	.81	1.97	2.50	.47x.39	16.85	12.00	12.15	G	200	226	22.75	16	1.12-7
20	23.25	5.00	19.25	21.59	17.25	8.27	6.50	4	.81	1.97	2.50	.47x.39	18.73	14.00	14.00	G	260	305	25.00	20	1.12-7

Note: K dimension is disc chordal dimension at valve face.

METRIC DIMENSIONS: Millimeters																	Lug Bolting Data				
Valve Size	A	B	C	D	E	F	Top Plate Drilling			G	J	Key Size	K	L		Adapter Code	Weight (Kg)		Bolt Circle	No of Holes	Threads ISO Coarse
							BC	No of Holes	Hole Diameter					Wafer	Lug		Wafer	Lug			
350	433	76.2	337	388	346	150	125	4	14	35	51	10x10	331	238	252	F	43	52	476	12	1.00-8
400	488	101.6	387	442	375	150	125	4	14	35	51	10x10	377	273	287	F	61	75	540	16	1.00-8
450	536	108.0	438	495	406	210	165	4	21	50	64	12x10	428	305	309	G	91	103	578	16	1.12-7
500	591	127.0	489	548	438	210	165	4	21	50	64	12x10	476	348	358	G	118	138	635	20	1.12-7

Note: K dimension is disc chordal dimension at valve face.

Drawings are for reference only. Bray reserves the right to change product dimensions without notice.